

Sunbeam

Healthy Food Dryer

INSTRUCTION BOOKLET.



Contents.

Sunbeam's Safety Precautions	2
An Introduction to Drying Techniques	3
Features of your Healthy Food Dryer	4
Care and Cleaning	6
Important Guidelines and Hints	6
Storage of Dried Foods	7
Rehydrating Dried Foods	7
Use of Dried Foods	7
Drying Fruits	8-9
Drying Vegetables	10-11
Fruit Rolls	12
Fruit Rolls Chart	12
Drying Herbs and Spices	13
Drying Meat	14
Drying Flowers	14
Recipes	15-18
Drying Records Chart	19-20

Sunbeam's Safety Precautions.

SAFETY PRECAUTIONS FOR YOUR HEALTHY FOOD DRYER.

- Use well away from walls and curtains.
- Avoid using on metal surfaces e.g. sink.

SAFETY PRECAUTIONS FOR ALL ELECTRICAL APPLIANCES

Sunbeam are very safety conscious when designing and manufacturing consumer products, but it is essential that the product user also exercise care when using an electrical appliance. Listed below are precautions which are essential for the safe use of an electrical appliance:

- **Read carefully and save all the instructions provided with an appliance.**
- Always turn the power off at the power outlet before you insert or remove a plug. Remove by grasping the plug - do not pull on the cord.
- Turn the power off and remove the plug when the appliance is not in use and before cleaning.
- Do not use your appliance with an extension cord unless this cord has been checked and tested by a qualified technician or service person.
- Always use your appliance from a power outlet of the voltage (A.C. only) marked on the appliance.
- Close supervision is necessary when your appliance is being used near children or infirm persons.
- Never leave an appliance unattended while in use.
- Young children should be supervised to ensure that they do not play with the appliance.
- Do not use an appliance for any purpose other than its intended use.
- Do not place an appliance on or near a hot gas flame, electric element or on a heated oven. Do not place on top of any other appliance.
- Do not let the power cord of an appliance hang over the edge of a table or bench top or touch any hot surface.
- For safety reasons and to avoid maintenance by unskilled persons, some appliances are 'sealed' using tamperproof screws. Such appliances should always be returned to the nearest Sunbeam Appointed Service Centre for adjustment or repair if required.
- Do not operate any electrical appliance with a damaged cord or after the appliance has been dropped or damaged in any manner. If damage is suspected, return the appliance to the nearest Sunbeam Appointed Service Centre for examination, repair or adjustment.
- For additional protection, Sunbeam recommend the use of a residual current device (RCD) with a tripping current not exceeding 30mA in the electrical circuit supplying power to your appliances.
- Do not immerse the appliance in water or any other liquid unless recommended.

If you have any concerns regarding the performance and use of your appliance, please ring our Toll Free number (Australia only) 1800 025 059. New Zealand - contact the Sunbeam Office in Auckland on 09 912 0747.

Ensure the above safety precautions are understood.

تأكد من تفهم احتياطات السلامة المذكورة اعلاه

請務必理解上述的安全預防措施。

Assurez-vous que les précautions ci-dessus relatives à la sécurité sont bien comprises

Versichern Sie sich daß die obenstehenden Sicherheitsmaßnahmen Verstanden werden

Βεβαιώστε πως οι παραπάνω προφυλάξεις ασφαλείας γίνονται κατανοητές

Pastikan bahwa tindakan-tindakan keselamatan seperti di atas dimengerti anda

Accertatevi che le suddette norme di sicurezza siano comprese a dovere

上記の注意事項をよくお読みになり、安全を御確認ください

Уверете се дека погоре споменатите мерки на претпазливост се добро разбрани

Asegúrese de que las precauciones de seguridad precedentes sean bien comprendidas

کاری بکنید کہ احتیاط‌های بالا حتماً درک بشوند

ต้องแน่ใจว่า ข้อควรระวังเรื่องความปลอดภัยข้างต้น เป็นที่เข้าใจกันดี

Yukarda belirtilen güvenlik önlemlerinin anlaşıldığından emin olunuz

Xin kiểm chắc rằng những biện pháp làm an toàn kể trên được hiểu rõ

An Introduction to Drying Techniques.

Congratulations on the purchase of your Sunbeam Healthy Food Dryer. You can now enjoy all the benefits of drying food in an easy economical fashion, at home.

How it works

Dehydrating food is an ancient method of preserving food. It is a gentle, natural process which removes moisture from food. Using a controlled heat temperature, air is circulated from the top of the unit to each of the five trays and base. This method of drying seals in the flavours and nutrients of the food, leaving a high food nutrient and vitamin content.

Storage of dried food

Drying fresh, ripe fruit and vegetables allows you to enjoy these luxuries all year round. Storing of food is easy and takes up little storage space. Dried food has a long shelf life in air tight storage jars of approximately 4-6 months depending on type of food and climate. Most vegetables have a much longer shelf life than fruits.

No preservatives added

Fruit and vegetables dried using your Healthy Food Dryer, will differ in colour and appearance from produce purchased from Health Food Stores and supermarkets. This is due to these stores adding artificial colouring and preservatives to the produce. Whereas your Healthy Food Dryer uses no preservatives and only natural additives.

Versatility

You can dry herbs and spices and flowers to make potpourri. You can even enjoy the advantages of rehydrating foods to make instant additions to soups, sauces and casseroles. The choice is endless.

Healthy snacks

Natural healthy snacks can easily be created using your Healthy Food Dryer. A variety of fruit rolls such as pear, berry and apple rolls, to name a few. You can make tasty, low calorie muesli bars, using all natural ingredients. These snacks are great for picnics, camping and at snack time.

Features of your Healthy Food Dryer.

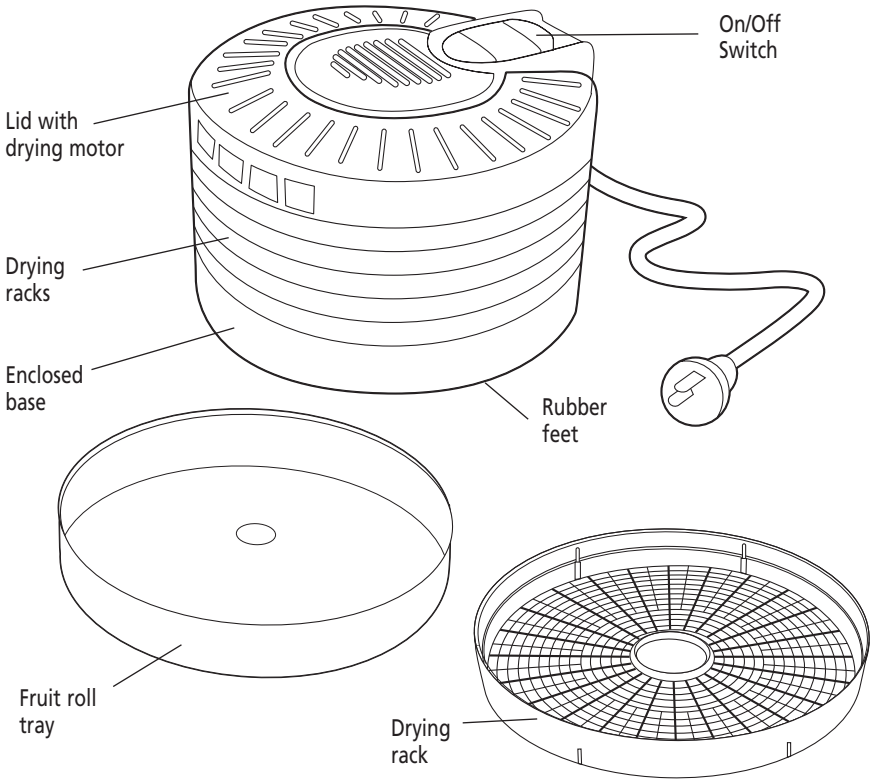

Lid with Drying Motor

Acts as a lid for the Healthy Food Dryer and contains the motor and ON/OFF switch. Air vents on the lid allow air to be circulated.

Drying Racks

Holds the food in place for easy drying. Each rack holds for example, approximately 3 sliced apples. Your unit includes 5 Drying Racks. You can purchase more Drying Racks from retail outlets and Sunbeam Service Centres (see listing at back of booklet).

Enclosed Base

The base can be used for making fruit and vegetable rolls, drying herbs and potpourri.

Rubber Feet

Holds the Healthy Food Dryer in place and prevents it from scratching the benchtop.

On/Off Switch

Enables the Drying Motor to be switched on and off.

Fruit Roll Tray

Able to make fruit and vegetable rolls.

Using your Healthy Food Dryer.

1. Arrange the food on the Drying Racks, ensuring the pieces of food are not quite touching, to allow air to circulate freely. Place Drying Racks onto the Base, ensuring that all racks are securely positioned in the grooves.
2. Place the Lid on the top Drying Rack. Plug the power cord into a 230/240 volt power outlet, and turn the power on. Push the large ON/OFF switch on the Healthy Food Dryer forward, towards the centre, to commence drying.

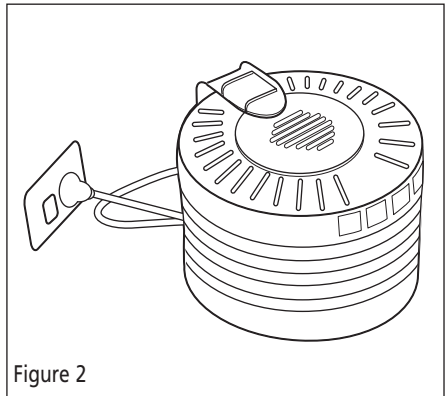
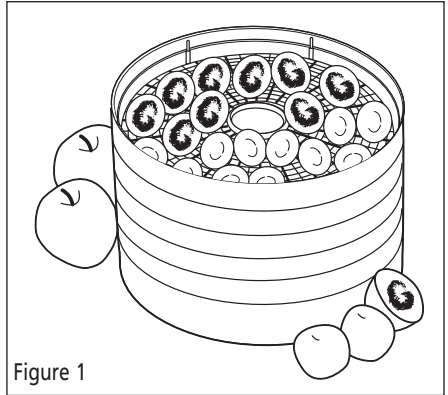

NOTE: If only using base of Food Dryer ensure an empty drying rack is inserted between the Lid and Base, to avoid restriction of air flow.

Sunbeam is a registered trademark. Healthy Food Dryer is a trademark of the Sunbeam Corporation. Made in China. Due to minor changes in design or otherwise, the product may differ from the one shown in this leaflet. Approved by the appropriate Electrical Regulatory Authorities. Backed by Sunbeam's 12 Month Replacement Guarantee and National Service Network.

© Copyright. SUNBEAM CORPORATION LIMITED 2002. (INCORPORATED IN N.S.W.) A.C.N. 000 006 771

For more information or advice on this or any other Sunbeam appliance, visit www.sunbeam.com.au or contact the Sunbeam Consumer Service Line.

Australia 1800 025 059
New Zealand (09) 912 0747.

Care and Cleaning.

- Do not immerse the Lid with Drying Motor in water. To clean, use a damp, soft sponge with a mild detergent.
- To clean the Drying Racks and the Base, soak in warm soapy water. A soft bristle brush can be used to loosen stubborn food particles.

Do not use steel wool, scouring pads or abrasive cleaners. In addition, do not place any parts in a dishwasher.

Important Guidelines and Hints.

Use Quality Food (if available)

Best results are achieved when quality food is used. Select produce at the peak of ripeness, colour and flavour, for the highest nutritional content.

You can dry overripe produce successfully, as long as you remove any poor areas.

Wash Food

Food should be washed thoroughly, removing soft or spoiled areas. Be certain that your hands, cutting utensils and food preparation areas are clean.

Cut Food Uniformly

produce can be shredded, sliced or diced, 5mm (1/4") slices are best for efficient drying.

Variation in Drying Times

Drying times are affected by the size of the load, thickness of the sliced produce, humidity in the air and the moisture content of the food itself. (Therefore, broad drying times have been given in the drying tables).

NOTE: The food dryer may be left on overnight, however this may not achieve optimum result. We recommend the rotation of drying racks every 3-4 hours throughout drying time to achieve even drying.

Testing for Dryness

Be sure to let the produce cool before testing for dryness. To test for dryness, cut a piece open – there should be no visible moisture inside.

Uneven Drying

If you notice uneven drying, rotate the drying racks, i.e. move the bottom rack to the top and the top racks down.

Keep Records

Records of humidity, weight of produce before and after drying times, will be helpful in improving your drying techniques for the future. use the Drying Record Chart provided (See page 19).

Availability of Drying Racks

Your Healthy Food Dryer is expandable to 10 Drying Racks at once. However, the drying times will be affected (i.e. each additional Drying Rack results in the produce taking one to two hours longer to dry).

NOTE: Rotation of racks every 3-4 hours is recommended when using additional racks. This will ensure even drying of food.

Storage of Dried Foods.

- Containers should be moisture and insect free. Glass jars with metal screw lids are ideal containers. Food stored in plastic bags, should be stored inside an insect proof container.
- The storage area should be cool, dry and as dark as possible. The ideal temperature for storing dehydrated food is 5-20°C.
- Dried food can be covered in plastic wrap and stored in a container in the freezer.

Important

Check for moisture by shaking the content of your storage container several times during the first week after the food has been dried. If moisture appears on the inside, the food has not been sufficiently dried and should be returned to the Healthy Food Dryer, for further drying. Do not place warm produce into storage containers, as condensation will form causing mould and mildew.

Rehydrating Dried Foods.

- Rehydration is the process of putting the moisture back into foods that have been dried.
- Dried foods can be partially rehydrated by soaking in water or cooking.
- To conserve the nutritional value of the rehydrated food, use the liquid remaining after soaking or cooking, in the rehydration recipes.
- One cup of dried vegetables generally reconstitutes to two cups of vegetables.
- One cup of dried fruit reconstitutes to one and a half cups of fruit.

Use of Dried Foods.

Rehydrated fruits and vegetables can be used in a variety of dishes. that can be used to make:

sauces	casseroles	marinated vegetables
cakes	salads	pies
soups	cereals	pasta dishes
stir fries	meat and poultry dishes	stuffing

Foods such as garlic, chillies and tomatoes can be bottled in olive oil and stored in a cool dry place for several months.

Drying Fruits.

Preparation

- Wash food and pat dry with paper towels.
- Remove any blemishes, pips and stones.
- Slice as recommended.
- Pre-treat where recommended.

NOTE: Food may be peeled or unpeeled when drying. Try drying both ways to distinguish preferred outcome.

Pre-Treatment

The pre-treatment of food where recommended helps retard browning whilst the food is drying.

- Where recommended use a natural pre-treatment of pineapple or lemon juice. Soak fruit for 3-4 minutes in the juice before placing on drying racks.

Blanching

- Some fruits with natural protective wax coatings e.g. figs, grapes and prunes, need to be blanched to speed the drying process.

To Blanch

1. Soak fruits in boiling water for 1-2 minutes.
2. Plunge into ice cold water.
3. slice and commence drying.

Dryness Test

- Cool fruit before testing for the final degree of dryness.
- Most fruit will be soft and pliable when properly dried.

Drying Chart for Fruit.

Expect a variance in the time needed to dry different foods. Drying times are affected by the size of the load, thickness of slices, humidity and temperature in your home.

NOTE: Times slated are based on drying using live racks. Times will vary depending on number of racks used.

Fruit	Preparation	Pre-Treatment	DrynessTest	Time
Apples	Core and slice into 5mm slices.	Dip slices in pre-treatment dip.	Pliable	8-12 hrs
Apricots	Cut in half, stone, turn inside out or slice in quarters.	Soak in pre-treatment for 2 minutes.	Pliable	12-18 hrs
Bananas	Peel & slice into 5mm slices.	Dip into lemon juice or sprinkle with brown sugar.	Pliable	12-18 hrs
Berries	Remove stalks. Slice if large e.g. strawberries.	None	Crisp	7-12 hrs
Cherries	Remove stems, cut in half & remove stones. Place skin side down on Drying Rack.	None	Leathery	10-14 hrs
Citrus fruits	Slice in 5mm slices.	None	Crisp	12-18 hrs
Coconut	Remove liquid and grate flesh from the shell.	None	Crisp	16-20 hrs

Drying Chart for Fruit (cont).

Fruit	Preparation	Pre-Treatment	DrynessTest	Time
Figs	Remove stems and halve or quarter. Place skin side down on Drying Rack.	Blanch	Leathery	12-18 hrs
Grapes	Seedless variety is preferable. Remove from stems and halve.	Blanch	Pliable	18-22 hrs
Kiwi Fruit	Peel and slice into 5mm slices.	None	Pliable	10-12 hrs
Mangoes	Peel and slice lengthwise into 5mm strips.	None	Pliable	8-10 hrs
Melons	Remove skin and seeds. Slice 5mm slices.	None	Leathery	10-16 hrs
Nectarines	Halve, remove stone, slice or quarter. Place skin side down on Drying Rack.	Soak in	Pliable	10-16 hrs
Paw Paw	Peel and remove black seeds. Slice lengthwise into thin strips.	None	Leathery	10-16 hrs
Peaches	Peel, halve and remove stone. Cut into 5mm slices.	Soak in pre-treatment for 2 minutes.	Leathery and Pliable	10-16 hrs
Pears	Peel thinly, core and slice into 5mm strips.	Soak in pre-treatment for 2 minutes.	Leathery	10-12 hrs
Pineapple	Peel, remove eyes and core. Cut into 5mm slices or wedges.	None	Pliable	14-16 hrs
Plums	Halve and remove stone. Slice into 5mm slices.	None	Leathery	12-16 hrs
Rhubarb	Trim and slice into 25mm lengths.	None	Brittle	10-12 hrs

Drying Vegetables.

Preparation

- Wash vegetables thoroughly and remove blemishes.
- Pre treat where recommended.

Pre-Treatment

- Steam Blanching: is needed to speed up drying process for certain vegetables.

To Steam Blanch

1. Bring saucepan of water to the boil.
2. Place vegetables in a colander in the saucepan and cover or alternatively steam the vegetables in the microwave.
3. Steam for as long as suggested in the Drying Chart below.
4. Cool in ice water, drain and pat vegetables dry.

5. Commence drying.

- Blanching: Preserves the colour, stops the ripening process and generally makes the produce dry faster.

To Blanch

1. Soak vegetables in boiling water for 1-2 minutes.
2. Plunge into ice cold water.
3. Slice and commence drying.

Dryness Test

- Cool vegetables before attempting the final test for dryness.
- Vegetables should feel hard and firm with no soft spots.

Drying Chart for Vegetables.

Expect a variance in the time needed to dry different foods. Drying times are affected by the size of the load, thickness of slices, humidity and temperature in your home.

Vegetable	Preparation	Pre-Treatment	DrynessTest	Time
Artichoke Hearts	Cut hearts into 5mm thick strips.	Steam until tender.	Brittle	8-12 hrs
Asparagus	Cut into 20mm length pieces.	Steam blanch for 4-5 minutes.	Brittle	8-10 hrs
Beans	Cut thinly on long angle. (French Style)	Steam blanch until translucent.	Brittle	6-8 hrs
Beetroot	Trim so that 10mm of the tops remain. Remove skin and slice in 5mm strips.	Cook until tender.	Brittle	12-14 hrs
Broccoli	Trim into flowerettes. Soak in salt water for 5 minutes, to remove hidden insects.	Steam blanch.	Brittle	10-12 hrs
Brussel Sprouts	Remove outer leaves, cut in half.	Steam blanch for 3 minutes.	Brittle	10-14 hrs

Drying Chart for Vegetables (cont).

Vegetable	Preparation	Pre-Treatment	DrynessTest	Time
Cabbage	Cut into strips.	Steam blanch for 4-5 minutes.	Leathery	10-12 hrs
Carrots	Trim tops, peel, cut into cubes or slices.	Steam blanch for 5 minutes.	Leathery	10-12 hrs
Cauliflower	Cut into flowerettes. flowerettes.	Steam blanch for 3 minutes.	Brittle	10-12 hrs
Celery	Cut into lengths	None	Crisp	8-10 hrs
Corn	Husk and trim the cobs.	Steam until just cooked. Remove kernels and dry on the Base.	Brittle	10-12 hrs
Eggplant	Slice into 5mm slices.	Steam blanch for 5 minutes.	Leathery	10-12 hrs
Mushrooms	Remove stem. Cut into slices or dry caps whole.	None	Crisp	6-8 hrs
Onions	Remove skins, tips and roots. Slice into 5mm slices.	None	Crisp	8-10 hrs
Peas	Shell and wash.	Steam blanch until they indent.	Brittle	6-8 hrs
Peppers Red/Green	Remove seeds. Cut into strips.	None	Brittle	6-8 hrs
Spinach Silver Beet	Trim leaves from stems.	Steam blanch for 1 minute. Do not bunch together on Drying Racks.	Brittle	5-7 hrs
Potatoes	Peel and slice into 5mm strips.	Steam blanch.	Crisp	10-12 hrs
Tomatoes	Remove stems, slice into 5mm slices.	None	Leathery	8-10 hrs
Cherry Tomatoes	Halve	None	Leathery	8-10 hrs
Zucchini	Remove ends, slice into 5mm slices.	Steam blanch for 2 minutes.	Pliable	8-10 hrs

Fruit Rolls.

Fruit rolls are dried, rolled sheets of plain or sweetened pureed fruit. They are healthy, nutritious snacks that the whole family will enjoy. Vegetables can also be in this way.

Preparation Directions

1. Place fruit roll sheet on drying rack.
2. Puree fresh or canned fruit to a consistency that can be spread easily with a spatula.

NOTE: Drain syrup from canned fruit or vegetables before pureeing.

3. Spread the puree over the fruit roll sheet, to a maximum thickness of 5mm Commence the drying process.
4. Fruit Rolls are ready when the centres are no longer sticky to touch.
5. Remove the fruit while it is still warm to prevent sticking.
6. Roll tightly and slice into desired portions.

Fruit Rolls Chart.

NOTE: Times will vary depending on number of fruit roll sheets used.

Fruit	Flavourings	Drying Time
Apples	Flavourings and Spices (to be added)	10 hrs
Apricots	Brandy, honey, lemon juice	10 hrs
Bananas	Vanilla, ginger, lemon juice	10 hrs
Cherries	Lemon juice, almond essence	10 hrs
Oranges	Cinnamon, lemon juice	10 hrs
Peaches	Honey, cinnamon, nutmeg	10 hrs
Pears	Lemon juice, nutmeg	10 hrs
Pineapples	Cinnamon, honey	10 hrs
Plums	Honey, lemon juice	10 hrs
Rhubarb	Honey, sugar	10 hrs
Strawberries	Cointreau, lemon juice, honey	10 hrs
Watermelon	Lemon juice	10 hrs

Drying Herbs and Spices.

Drying your own herbs and spices is an easy, economical way to make the most from your herb garden.

Hints

- Pick leaves, when young and tender.
- Pick seed pods before they open.
- Most herbs and spices can be dried on the plant stalk or stem.

The leaves and seeds are easily stripped off once they are dry.

- Do not store herbs in paper bags as the oils will be absorbed by the paper leading to less flavour.
- Store in a cool, dark place in an airtight container.

Drying Chart for Herbs and Spices.

Herb/Spice	Preparation	Drying Time	Use
Basil	Wash, place leaves onto Drying Racks	4-6 hrs	Soups, sauces
Chives	Wash, slice into desired lengths.	6-8 hrs	Salads, casseroles and soups
Coriander	Wash, place whole stems onto Drying Racks.	6-8 hrs	Curries, Thai dishes and soups
Garlic	Peel and chop, dry in the Base.	6-8 hrs	Casseroles, soups and pasta
Ginger	Grate or slice, place onto Drying Racks.	6-8 hrs	Cakes and curries
Marjoram	Wash, place whole stems onto Drying Racks.	6-8 hrs	Casseroles and soups
Mint	Wash, place whole stems onto Drying Racks.	6-8 hrs	Thai dishes and sauces
Oregano	Wash, place whole stems onto Drying Racks.	6-8 hrs	Soups, casseroles and pasta
Parsley	Wash, place whole stems onto Drying Racks.	4-6 hrs	Soups and casseroles
Thyme	Wash, place whole stems onto Drying Racks.	4-6 hrs	Soups and casseroles

Drying Meat.

Preparation Directions

1. Trim excess fat from the meat and slice into strips.
2. Marinate meat in the refrigerator for 6-8 hours.
3. Dry meat in an uninterrupted drying cycle for 8-10 hours.

Storage

Store dried meat in an air tight jar. Refrigerate if storing for any length of time. The recommended shelf life is 3 months. Be sure to test for dryness every 2-3 weeks. (See page 6).

Drying Flowers.

Using your Healthy Food Dryer, you are able to dry your own flowers, blossoms and petals.

Hints

- As flowers darken when they dry, try to select flowers which are several shades lighter.

Preparation Directions

1. Cut flowers when they are dry and cool.
2. Choose flowers that are firm but only half open. Full bloom flowers tend to lose their petals.
3. Position flowers and petals sparsely on the Drying Racks and Base.
4. Dry for 8-10 hours until flowers are brittle.

Potpourri

To make potpourri: use handful of flowers, blossoms and petals and combine with 3-4 drops of perfumed oil e.g. tea rose or lavender.

Preparation Directions

1. Arrange flowers, blossoms and petals sparsely on the Drying Racks and Base.
2. Dry for 6-8 hours.
3. Place in a large air tight glass container with 3-4 drops of perfumed oil, to enliven the fragrance. After a month, shake the petals or sprinkle more oil into the container.

Recipes.

SOUPS

Dried Vegetable Soup

- 1 cup dried tomatoes*
- 1 cup dried carrots*
- 1 cup dried beans*
- 1 cup dried celery*
- 1 cup dried peas*
- 1½ litres of water*

Dried parsley

1. Cover vegetables with water in a saucepan.
2. Add parsley and stir until it boils.
3. Cover and simmer for about 2 hours or until vegetables are soft.

CEREALS/SNACKS

Muesli

- 2 cups rolled oats*
- ¼ cup oil*
- ¼ cup brown sugar*
- ¼ cup sunflower seeds*
- ½ cup chopped dried apricots*
- ¼ cup raisins*

1. Combine rolled oats, oil and brown sugar in a bowl, loss until mixed.
2. Place mixture into the Base of the Healthy Food Dryer and commence drying.
3. Approximate drying time is 10-12 hours.
4. Once drying is complete, add dried apricots and raisins.
5. Store in an air tight container, in a cool spot.

Muesli Bars

- ¼ cup brown sugar (optional)*
 - ½ cup peanut butter*
 - 3 tablespoons butter*
 - ¼ cup of water*
 - 2 cups of muesli*
1. Combine brown sugar (optional), peanut butter and butter in a saucepan. heat until melted. Add water.
 2. Mix well with muesli mix.
 3. Press into a foil lined slice tine. Cool in refrigerator for 2 hours.
 4. Slice into bars.
 5. Dry 8-10 hours on Drying Racks until chewy.

Marinated Medley

- 100g dried red capsicum, sliced*
 - 100g dried green capsicum, sliced*
 - 1 cup oil*
 - 1 tablespoon dried oregano, finely chopped*
 - 1 tablespoon dried oregano, finely chopped*
 - 1 tablespoon dried basil, finely chopped*
 - 1 clove dried garlic, finely chopped*
1. Combine all ingredients in a bowl and mix well.
 2. Store in an air tight jar, in a cool place.

Dried Tomatoes (in oil)

- 300g dried tomatoes*
 - 1 cup olive oil*
 - 1 tablespoon finely chopped fresh basil*
 - 1 tablespoon finely chopped fresh oregano*
1. Combine all ingredients in a bowl and mix well.
 2. Store in an air tight jar, in a cool place.

Recipes (cont).

MEAT

Beef Jerky

500 g steak sliced in 5mm strips.

Marinade

1/2 cup soy sauce

2 tablespoons Worcestershire sauce

1/2 tablespoon brown sugar

1 clove garlic, crushed

Black pepper and curry powder to taste

1/2 teaspoon salt

1. Combine marinade ingredients. Add the meat.
2. Marinate the meat for 6-8 hours or overnight in the refrigerator.
3. Drain meat and place on drying Racks.
4. Dry for 10-12 hours.
5. Meat will be bendable and pliable when ready.

CAKES

Banana Loaf

1 1/2 cups dried banana chips

3/4 cup butter/margarine

1 1/2 brown sugar

2 eggs

3/4 cup milk

1 1/4 teaspoons baking soda

1/2 cup crunchy peanut butter

2 cups self raising flour, sifted

1. Soak banana chips for one hour, in two cups of water.
2. Cream butter and sugar, add eggs and beat well.
3. Add drained bananas with half of the milk and heat again.
4. Add remaining liquid, peanut butter and sifted dry ingredients. Blend until smooth.
5. Pour into greased loaf tin.
6. Bake at 180°C for approximately one hour.

Carrot and Walnut Cake

2 cups boiling water

2 cups dried, grated carrot

1 cup sugar

1 cup vegetable oil

2 cups self raising flour, sifted

1 teaspoon baking powder

Pinch of salt

2 teaspoons cinnamon

4 eggs

1/2 cup walnuts, chopped

1. Combine carrots and boiling water, stand for 1 hour.
2. Drain carrots and add sugar and oil. Mix well.
3. Add dry ingredients, eggs and nuts.
4. Pour into a well greased cake tin.
5. Bake in a moderate oven for 30-35 minutes.

Date and Nut Loaf

60g butter

1/2 cup brown sugar

1 egg, lightly beaten

150ml milk

3/4 cup dried dates, chopped

1/2 cup walnuts, chopped

1 1/2 cups self raising flour

1. Preheat oven to 180°C. Cream butter and sugar in a bowl. Add beaten egg.
 2. Blend in milk, dried dates and walnuts. Gently fold in flour. Pour into greased and lined 14cm x 21cm loaf tin.
 3. Bake for 30-40 minutes. Remove from tin and allow to cool before slicing.
- Serve warm or cold with butter.

Recipes (cont).

Apricot Muffins

1/2 cup margarine

1/2 cup sugar

2 eggs

1 cup milk

grated rind and juice of 1 orange

3/4 cup dried apricots, chopped

1 1/2 cups self raising flour

1. Preheat oven to 180°C and grease bottoms of twelve muffin tins.
2. Blend margarine and sugar, beat in remaining wet ingredients.
3. Fold in flour, apricots and orange rind and place mixture into prepared muffin tins.
4. Bake at 180°C for 25 minutes.

Peanut Butter Fruit Spread

1 cup crunchy peanut butter

2 tablespoons butter, softened

1/2 cup finely chopped dried fruit (applies, apricots, dates)

1 tablespoon lemon juice

2 tablespoons honey

1. In a small bowl, combine all ingredients and beat until smooth and well mixed.
2. Serve as a spread on crackers or bread.

VEGETABLES

Zucchini Bake

2 cups boiling water

2 cups dried zucchini slices

1 medium onion, thinly sliced

2 1/2 tablespoons oil

1 cup fresh or canned tomatoes

salt and pepper

1/2 cup mozzarella cheese, grated

1. Pour boiling water over dried zucchini slices and allow to soak 1 to 2 hours. Drain.
2. Cook onion slices in oil until transparent. Add drained zucchini slices. Cook and stir for 5 minutes.
3. Add tomatoes, and season to taste with salt and pepper.
4. Pour into greased baking dish and top with grated cheese.
5. Bake at 180°C for 25-30 minutes, or until lightly browned.

Sweet Potato Strips

1 1/2 cups boiling water

1 1/2 cups dried sweet potato strips

1 egg, well beaten

1/2 cup dry breadcrumbs

oil, for frying

1. Pour boiling water over potato strips. Allow to soak for one hour.
2. Drain excess liquid and wipe strips. Dip strips in beaten egg, then coat in breadcrumbs.
3. Fry in oil until golden brown.

Recipes (cont).

Banana Oatmeal and Walnut Biscuits

3/4 cup dried banana chips

1 1/2 cups plain flour

1 teaspoon baking powder

1 teaspoon ground cinnamon

1/4 teaspoon bicarbonate of soda

1/4 teaspoon ground nutmeg

1/4 cup sugar

pinch salt

185g butter or margarine softened

2 eggs

1 1/2 cups rolled oats

1 1/2 cups chopped walnuts or peanuts

1. Soak banana chips for one hour in one cup of hot water. Drain water and puree.
2. Sift together flour, baking powder, cinnamon, soda, nutmeg and salt.
3. Add sugar, softened butter or margarine, eggs and half the pureed bananas. Beat until combined.
4. Fold in remaining bananas, oats and walnuts.
5. Drop teaspoon fulls onto greased baking tray.
6. Bake at 180°C in a preheated oven until firm and golden, 12-15 minutes. Allow to cool slightly before transferring to wire rack.

Herb Scones

2 cups self raising flour

30g butter or margarine

1 tablespoon sugar

pinch salt

2/3 cup milk

2 teaspoons dried herbs

1. Preheat oven to 220°C.
2. Mix all ingredients except milk until mixture resembles breadcrumbs.
3. Add milk gradually, while mixing until a soft dough ball forms.
4. Turn out onto floured board. Knead lightly. Press or roll out to 2cm thickness and cut with a floured scone cutter.
5. Place close together on greased tray and glaze with milk. Bake for 10-12 minutes.

Drying Records Chart.

Produce	Date	Weight of produce (before drying)	Pre-treatment	Humidity 1. 5 (low) (high)	Time drying started	Time drying finished	Weight of dried produce

Drying Records Chart.

Produce	Date	Weight of produce (before drying)	Pre-treatment	Humidity 1. 5 (low) (high)	Time drying started	Time drying finished	Weight of dried produce